

AN INVESTIGATION ON SENSOR BASED RECOGNITION SYSTEM FOR DISABLED

***Dr. S.R.BOSELIN PRABHU, ** Dr. E.GAJENDRAN, ***N. BALAKUMAR**

**Assistant Professor, Department of Electronics and Communication Engineering,
SVS College of Engineering, Coimbatore, India.*

***Professor, Department of Information Technology,
St.Martin''s Engineering College, Hyderabad.*

**** Assistant Professor, Department of Electrical and Electronics Engineering,
Tamilnadu College of Engineering, Coimbatore, Tamilnadu, India.*

ABSTRACT

Home automation or smart home (also known as domotics or domotica) is the residential extension of building automation and involves the control and automation of lighting, heating (such as smart thermostats), ventilation, air conditioning (HVAC), and security, as well as home appliances such as washer/dryers, ovens or refrigerators/freezers that use Wi-Fi for remote monitoring. Modern systems generally consist of switches and sensors connected to a central hub sometimes called a "gateway" from which the system is controlled with a user interface that is interacted either with a wall-mounted terminal, mobile phone software, tablet computer or a web interface, often but not always via internet cloud services. Zigbee has a defined rate of 250 kbits/s, best suited for periodic or intermittent data or a single signal transmission from a sensor or input device. The wireless home Automation systems is supposed to be implemented in existing home environments, without any changes in the infrastructure. This system is most suitable for the elderly and the disabled persons especially those who live alone and since recognize voice so it is secure. The home automation system is intended to control all lights and electrical appliances in a home or office using voice commands.

Keywords: Home automation, Microcontroller, Voice Recognition, ZigBee, Power Supply.

1. INTRODUCTION

A remote control system for lamps and appliances from X10 Wireless Technology that uses the home's electrical system as the signalling network. The standard powerline system since it was developed in 1975 for many years, x10 transmitters and receivers are set to one of 256 low-voltage codes. The controller, which contains the switch and transmitter, is an external unit that plugs into any AC outlet, or it replaces the light switch on the wall. The receiver plugs into the AC outlet, and the lamp or appliance plugs into the receiver. When the switch is activated, it sends a signal into the electrical line that is picked up by the receiver, which turns on/off or dims the lights. Several lamps can be treated as one group by setting their receivers to the same code. RF is 310 MHz in North America and 433 MHz in Europe [1-11].

ZigBee PRO and ZigBee Remote Control (RF4CE), among other available ZigBee profiles, are based on the IEEE 802.15.4 protocol, which is an industry-standard wireless networking technology operating at 2.4 GHz targeting applications that require relatively infrequent data

exchanges at low data-rates over a restricted area and within a 100 m range such as in a home or building. Additional radio frequencies used are 915 MHz (Americas and Australia) and 868 MHz (Europe). The project demonstrates a system that can be integrated as a single portable unit and allows one to wirelessly control lights, fans, air conditioners, television sets, security cameras, electronic doors, computer systems, audio/visual equipment's etc. The overall system is controlled from a microphone which is connected with HM 2007 speech recognition chip. This chip sends the voice commands in binary sequence to microcontroller. The remote system receives the commands through ZigBee transceiver and performs the request function [12-15].

2. SYSTEM OVERVIEW

The base station will operate with a +5V power supply. This voltage will be used as the operating voltage for all of the circuit elements in the base station. The microphone in the base station will be picking up audio in a close range. The audio signal from the microphone will be input into the HM 2007 speech recognition chip. The HM 2007 chip will process the audio and determine if the commands are speech commands and valid then it will pass the commands through microcontroller and ZigBee to remote station where the matched command operation will be performed. A 16 x 2 LCD interfaces with the microcontroller to display the current status of the sensors and relay switches on/off state. A sound alarm is given in the base station as well as in the remote station which indicate the status of water level either water in the tank is overflowing (To off the water motor) or below limit (To on). The HM 2007 chip does voice analysis and recognition on the microphone audio signals. The HM 2007 interfaces directly with a microphone and the microcontroller in turn interfaced with ZigBee transceiver. The word length to be recognized will be selected to be the highest amount of 1.92 seconds. This will allow a maximum of 20 words to be memorized with the 8K-byte memory used. This will suit the needs of our product, as the speech commands will never surpass 20 words. Measuring the change in signals strength between the access Point and can accordingly turn on or off appliances such as lights and fans and in the meantime send its status back to base station [16-27].



Figure 1 Transmitter Module

The remote station will operate with same +5 V power supply. The remote station microcontroller receives the digital signal commands from the base station using the Zigbee wireless protocol and performs the request function. On the basis of command signals received it

will update the status of relay switches board. It also read the sensors values and update the LCD status on the remote station. The sensors unit is capable of detecting when the user enters or leaves the room by measuring the change in signals strength between the access Point and can accordingly turn on or off appliances such as lights and fans and in the meantime send its status back to base station.

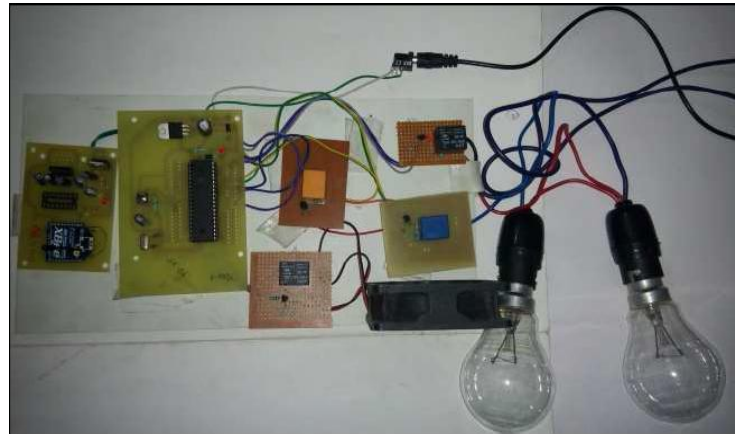

Figure 2 Receiver Module

3. PROJECT DESIGN METHODOLOGY

The project was divided into parts to make the design process modular. In the prototype board fabricated by the authors, these parts replaced with their specifications are:

3.1 Speech Recognition Unit: The heart of speech recognition system is HM2007 voice recognition IC. The IC can recognize 20 words, each word a length of 1.92 seconds

3.2 ZigBee: It is a low-cost, low-power, wireless networking standard. The low cost allows the technology to be widely deployed in wireless control and monitoring applications, the low power-usage allows longer life with smaller batteries, and different networking topologies provides high reliability and larger range.

3.3 Microcontroller: Any 8-bit microcontroller can be configured with the system. Here we have used 8051 microcontroller (AT89S51)-full static CMOS controller, 8k Flash memory, 256 bytes RAM, 4 I/O ports of 8 bit wide, 3 timers/counters, 8 interrupt sources etc.

Speech Recognition Unit

The speech recognition system is a completely assembled and easy to use programmable speech recognition circuit. Programmable, in the sense that we can train the words that we want the circuit to recognize. This circuit board allows us to experiment with many facets of speech recognition technology. It has 8 bit data out which can be interfaced with any microcontroller for further development.

HM2007

It is a single chip CMOS voice recognition LSI circuit with the on-chip analog front-end, voice analysis, recognition process and system control function. A 20 isolated word voice recognition system can be composed of external microphone, keyboard, 8K SRAM and other components, combined with a microcontroller, an intelligent recognition system can be built. It support two

control mode: Manual mode and CPU mode. It is also available in 48-pin PDIP. The pin description of HM2007 is shown above. The keypad and digital display are used to communicate with and program the HM2007 chip. The keypad is made up of 12 normally open momentary contact switches. The 74LS373 8-bit registers feature 3-state outputs designed specifically for driving highly capacitive or relatively low-impedance loads. The high-impedance 3-state and increased high-logic-level drive provide these registers with the capability of being connected directly to and driving the bus lines in a bus-organized system without need for interface or pull-up components. The IC 7448 is BCD to 7-segment common cathode IC. To display the data, we have to convert it from BCD to 7-segment code. The IC makes this process. It has four inputs called BCD inputs and seven outputs to drive the display. The voice recognition system schematic diagram is shown below in fig.4. A microphone is connected directly with pin 15(MICIN) of HM2007 which is shown below. On this system, voice is trained first and then recognized whenever a command is given through microphone.

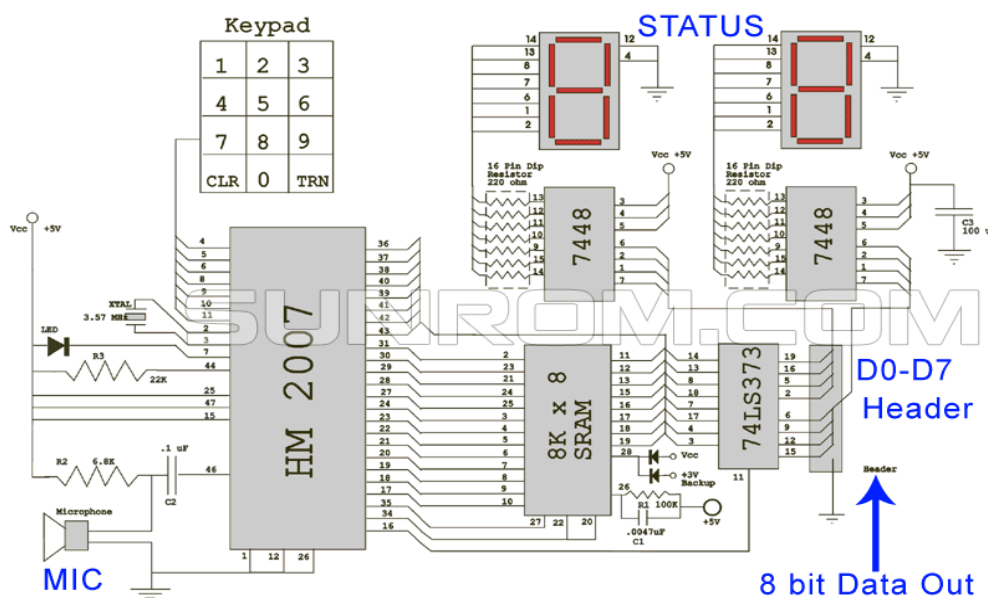

Figure 3 Functional Pin Description of HM 2007

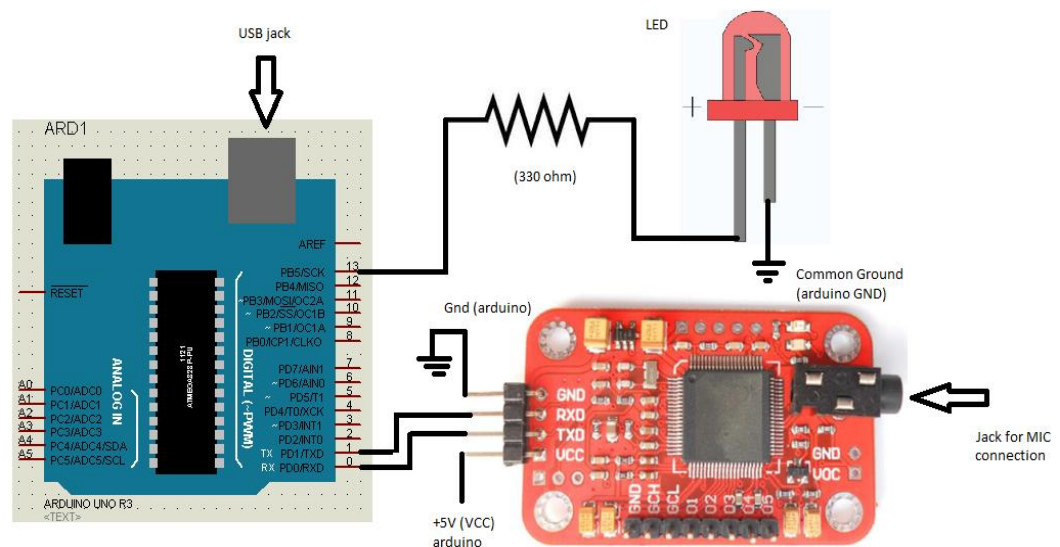

Figure 4 Schematic diagram

4. THE PROPOSED SYSTEM

There are two mode which are supported by this system, Manual mode and CPU mode.

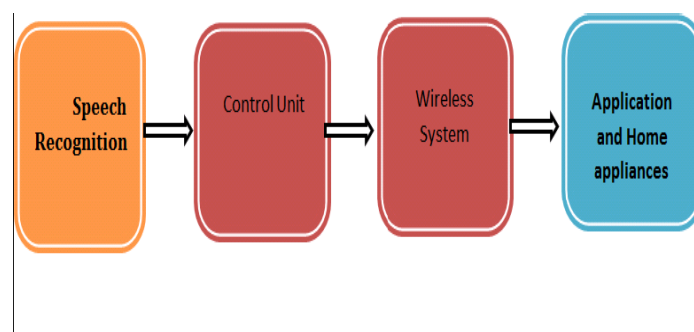

Figure 5 System model

Manual Mode

This mode is selected by connecting Pin 14(CPUM) to ground by using SPDT switch. When the circuit is turned on, “00” is on the digital display, the red LED (contacted with READY pin) is lit and the circuit waits for a command. By using this mode we can do following task:

- Training Words for Recognition:
- Testing Recognition:
- Error Codes Detection in 7-segment display. This happens when the voice command is too short or too long.
- Clearing Memory.

CPU Mode

This mode is used when we want to perform additional functions or want to make our system smart, this is done by connecting voice recognition system with the microcontroller. This mode is selected by connecting Pin 14(CPUM) to Vcc by using SPDT switch. In this mode K-bus is

used as a bidirectional data bus between the microcontroller and HM2007 and S1 to S3 as R/W control pins. The several function provide by CPU modes which are similar to manual mode are:

- RECOG
- TRAIN
- RESULT
- UPLOAD
- DOWNLOAD
- RESET

Zigbee

The explosion in wireless technology has seen the emergence of many standards, especially in the industrial, scientific and medical (ISM) radio band. There have been a multitude of proprietary protocols for control applications, which bottlenecked interfacing. Need for a widely accepted standard for communication between sensors in low data rate wireless networks was felt. As an answer to this dilemma, many companies forged an alliance to create a standard which would be accepted worldwide. It was this ZigBee Alliance that created ZigBee. Bluetooth and Wi-Fi should not be confused with ZigBee. Both Bluetooth and Wi-Fi have been developed for communication of large amount of data with complex structure like the media files, software etc. The ZigBee and ZigBee Pro radio is made by Digi (formerly Midstream) which is shipped with firmware implementing the IEEE 802.15.4 protocol. These modules use the IEEE 802.15.4 networking protocol for fast point-to-point or peer-to-peer networking. However, the most different part between ZigBee and ZigBee Pro is they have different cover distance range for communicate with own module. ZigBee can be covers around 30m at indoor and 100m at outdoor. Inversely, ZigBee Pro can cover higher distance range than ZigBee which is 100m at indoor and 1500m at outdoor. Both devices that have a UART interface so can be connected directly from microcontroller to pins of RF Module (ZigBee/ZigBee Pro). Using UART interface, we can use this wireless devices to communicate between microcontroller to microcontroller (two 8051's) or between PC to microcontroller or between PC to PC. Here. The role of the Zigbee module is to be as transparent as possible. It should be as if a wire was connecting the input to the output and connectivity is never lost. While this sounds simple, it's actually a very hard task to accomplish and error correction is a must, which the ZigBee's role in offering sound and reliable wireless communication.

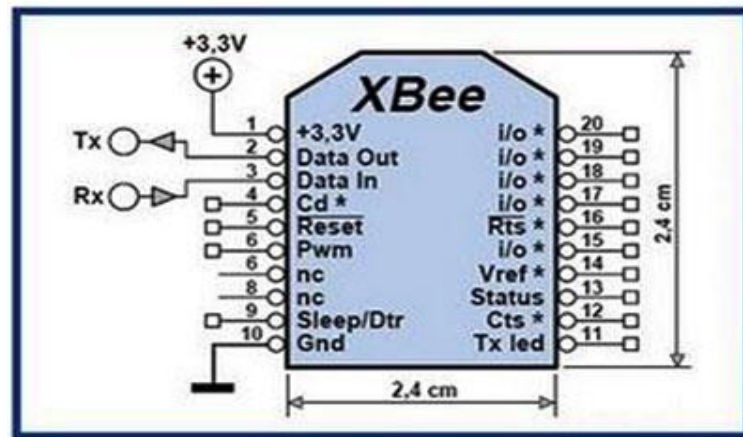

Figure 6 Zigbee pin configuration

Looking at the ZigBee pinout we can see right away the different types of input that can be translated and transmitted wirelessly:

- Digital I/O
- Analog I/O (10 bit resolution)
- Pulse with Modulation
- Serial Communication (SPI/RS232/I2C)
- CTS/DTR Control Signals

These are some the most common types of signals that are used in electronics and the ZigBee offer them all as inputs and outputs.

PIC16F877A Microcontroller

General purpose I/O pins can be considered the simplest of peripherals. They allow the PIC microcontroller to monitor and control other devices. To add flexibility and functionality to a device, some pins are multiplexed with an alternate function(s). These functions depend on which peripheral features are on the device. In general, when a peripheral is functioning, that pin may not be used as a general purpose I/O pin.

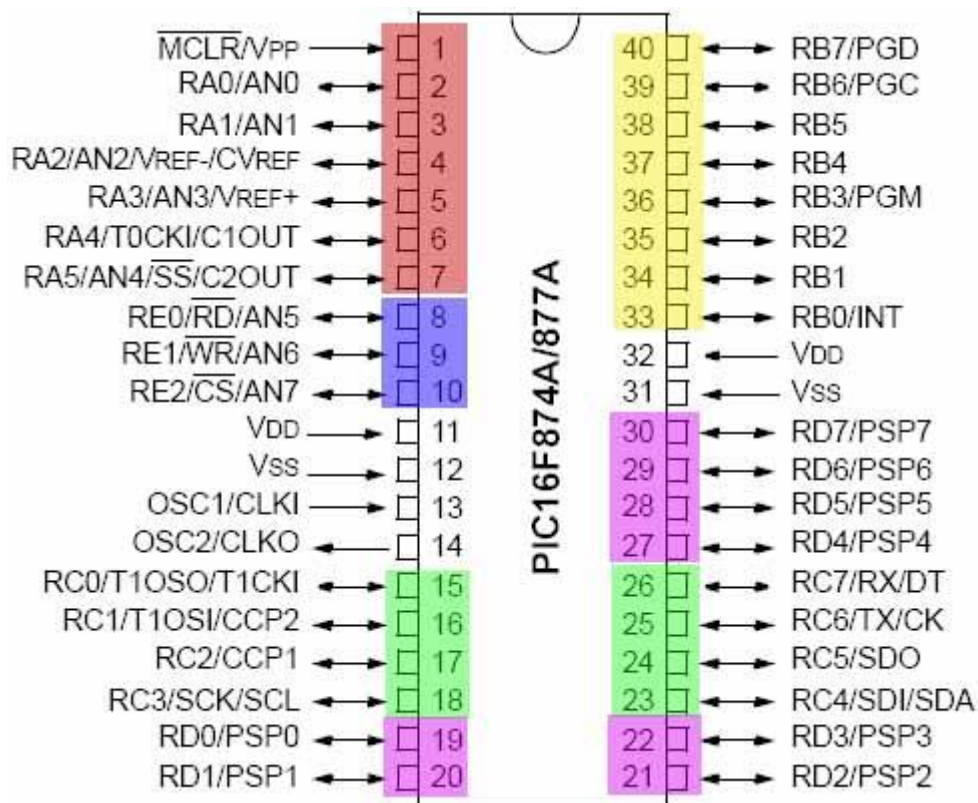

Figure 7 PIC 16F877A Pin Configuration

If pins are multiplexed with Analog inputs, then on a Power-on Reset these pins are configured as analog inputs, as controlled by the ADCON1 register. Reading port pins configured as analog inputs read a '0'.

If pins are multiplexed with comparator inputs, then on a Power-on Reset these pins are configured as analog inputs, as controlled by the CMCON register. Reading port pins configured as analog inputs read a '0'.

If pins are multiplexed with LCD driver segments, then on a Power-on Reset these pins are configured as LCD driver segments, as controlled by the LCDSE register. To configure the pins as a digital port, the corresponding bits in the LCDSE register must be cleared. Any bit set in the LCDSE register overrides any bit settings in the corresponding TRIS register.

Pins may be multiplexed with the Parallel Slave Port (PSP). For the PSP to function the I/O pins must be configured as digital inputs the PSPMODE bit must be set.

At present the Parallel Slave Port (PSP) is only multiplexed onto PORTD and PORTE. The microprocessor port becomes enabled when the PSPMODE bit is set. In this mode, the user must make sure that the TRISE bits are set (pins are configured as digital inputs) and that PORTE is configured for digital I/O. PORTD will override the values in the TRISD register. In this mode the PORTD and PORTE input buffers are TTL. The control bits for the PSP operation are located in TRISE.

Liquid Crystal Display (LCD)

Here we are using a 16 x 2 LCD for displaying the values on the screen. It has 16 pins. It support 16 characters per rows and total no of rows are 2. It means that it can support up to 32 character at a time, which is sufficient for data display purpose. RS, R/W and Enable pins of LCD are connected with the receiving end microcontroller port pins. Data lines D0-D7 are connected to one of the output port of microcontroller. Here VDD (contrast voltage) is adjusted by using a variable resistor connected with it.

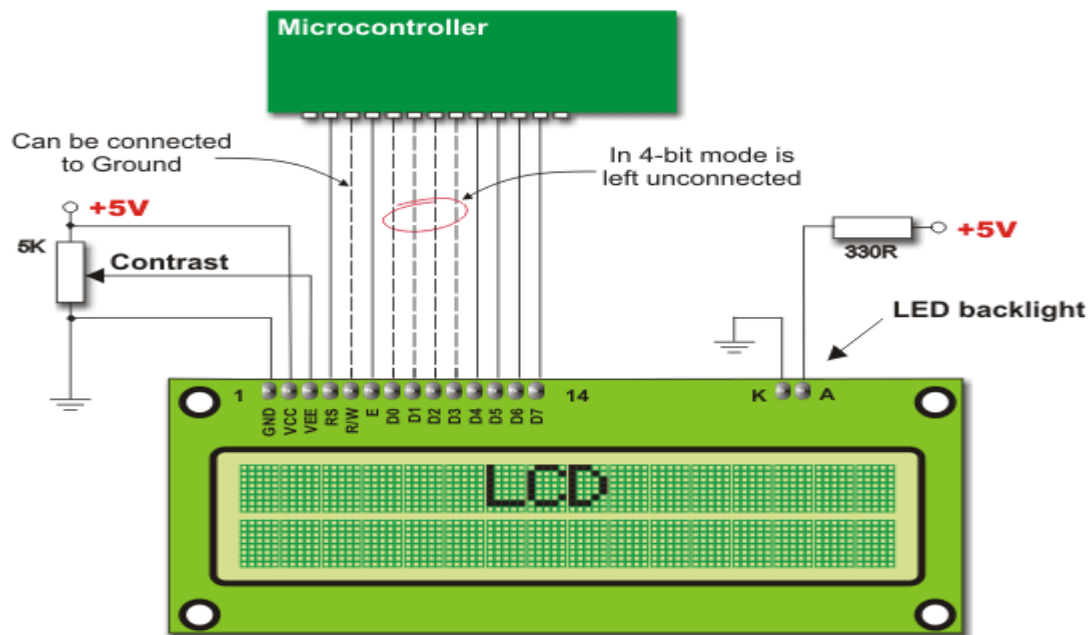

Figure 8 LCD Basic Connection

Power Supply Unit

In the power section a simple 9-12V battery is connected with the transmitting end as well as receiving end. Since the microcontroller which is the central processing unit works on regulated +5V power supply so this can be achieved by connecting a +5 volt regulator at the output of battery.

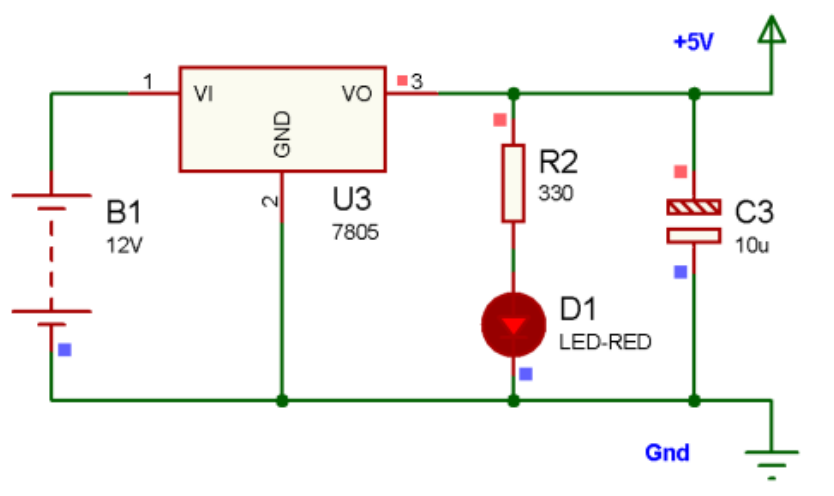

Figure 9 Battery operated +5V power supply

Other Components

A single relay switch connection to microcontroller are shown below. Any home appliance operating under A.C voltage supply could be connected directly with this relay interface circuit. A buzzer can also be connected by applying +12V at the common terminal of relay. Remaining relays of the interface circuit board could also be configured with the microcontroller in the similar fashion.

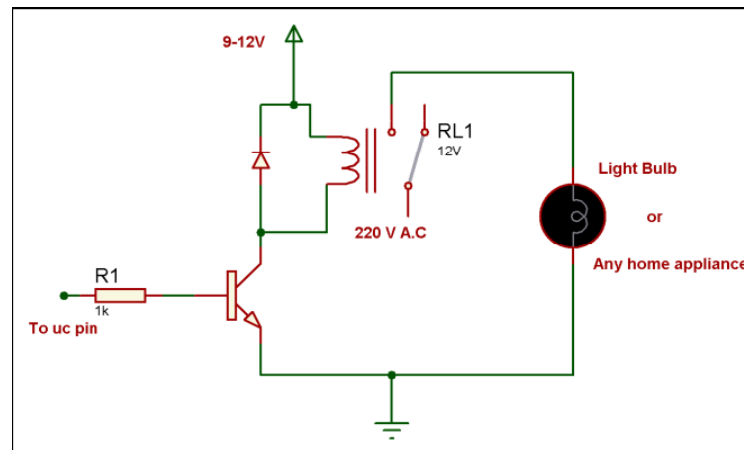

Figure 10 Relays switch board interfacing with the microcontroller

Similarly different sensors could be interface with the microcontroller by using analog to digital convertor or comparator circuit. So any sensors can be connected with the remote station according to the system requirement.

5. CONCLUSION

Voice recognition Wireless Home Automation Based on ZigBee is a very useful project for the adults and physically disabled persons, who are not able to do various activities efficiently when they are at home and need one's assistant to perform those tasks. ZigBee Home Automation provides operating range much higher as compared to Bluetooth and other wireless sensor module. With the use of ZigBee Home Automation circuit considerable amount of power saving is possible and it is flexible and compatible with future technologies so it can be easily customized for individual requirements. On the other hand with voice recognition system, it provides secure access to home.

REFERENCES

- [1]. Y.Usha Devi 1, II M.Tech, Wireless Home Automation System Using ZigBee, International Journal of Scientific & Engineering Research Volume 3, Issue 8, August-2012 ISSN 2229-5518.
- [2] Hamid Ali Abed Al-Asadi, "Temperature dependence of the lasing characteristics of vertical cavity surface emitting lasers," Engineering Journal of Technology University, Vol. 145, 1994.
- [3] Boselin Prabhu S.R. and Sophia S., "Environmental monitoring and greenhouse control by distributed sensor Network", International Journal of Advanced Networking and Applications, 5(5), 2014.

- [4] Boselin Prabhu S.R. and Sophia S., "Greenhouse control using wireless sensor network", *Scholars Journal of Engineering and Technology*, 2(4), 2014.
- [5] Hamid Ali Abed Al-Asadi, "Temperature dependence of the noise characteristics of Multiissection semiconductor lasers," *Science Journal*, vol. 7, No. 3, 2001.
- [6] Hamid Ali Abed Al-Asadi, "Linewidth characteristics of vertical cavity surface emitting lasers due to external optical feedback," *Science Journal*, vol. 8, 2001.
- [7] Boselin Prabhu S.R. and Sophia S., 'Modern cluster integration of advanced weapon system and wireless sensor based combat system', *Scholars Journal of Engineering and Technology*, 2(6A), 2014.
- [8] Boselin Prabhu S.R. and Sophia S., 'A review of efficient information delivery and clustering for drip irrigation management using WSN', *International Journal of Computer Science and Business Informatics*, 14(3), 2014.
- [9] Hamid Ali Abed Al-Asadi, "Linewidth characteristics of vertical cavity surface emitting lasers due to external optical feedback," *Science Journal*, vol. 8, 2002.
- [10] Hamid Ali Abed Al-Asadi, "Theoretical investigation of spectral linewidth properties of double fused 1.3 um MQW-VCA in reflection and transition modes," *Tikrit Journal for Pure Science*, vol. 8, No. 2, 2002.
- [11] Boselin Prabhu S.R. and Sophia S., 'Mobility assisted dynamic routing for mobile wireless sensor networks', *International Journal of Advanced Information Technology*, 3(3), 2013.
- [12] Boselin Prabhu S.R. and Sophia S., 'A review of energy efficient clustering algorithm for connecting wireless sensor network fields', *International Journal of Engineering Research and Technology*, 2(4), 2013.
- [13] Hamid Ali Abed Al-Asadi, "Vertical cavity amplifiers and its cavity length dependence the saturation power and quantum efficiency," *Tikrit Journal of Pure Science*, vol. 9, No. 2, 2003.
- [14] Hamid Ali Abed Al-Asadi, "Effects of pump recycling technique on stimulated Brillouin scattering threshold: A theoretical model," *Optics. Express*, Vol. 18, No. 21, pp. 22339-22347 Impact factor: 3.88, 2010.
- [15] Boselin Prabhu S.R. and Sophia S., 'Variable power energy efficient clustering for wireless sensor networks', *Australian Journal of Basic and Applied Sciences*, 7(7), 2013.
- [16] Boselin Prabhu S.R. and Sophia S., 'Capacity based clustering model for dense wireless sensor networks', *International Journal of Computer Science and Business Informatics*, 5(1), 2013.
- [17] Hamid Ali Abed Al-Asadi, "Brillouin Linewidth Characterization in Single Mode Large Effective Area Fiber through the Co-Pumped Technique," *International Journal of Electronics, Computer and Communications Technologies (IJECCCT)*, Vol. 1(1), pp. 16-20, 2010.

- [18] Boselin Prabhu S.R. and Sophia S., 'An integrated distributed clustering algorithm for dense WSNs', International Journal of Computer Science and Business Informatics, 8(1), 2013.
- [19] Boselin Prabhu S.R. and Sophia S., 'A research on decentralized clustering algorithms for dense wireless sensor networks', International Journal of Computer Applications, 57(20), 2012.
- [20] Hamid Ali Abed Al-Asadi, "Analytical study of nonlinear phase shift through stimulated Brillouin scattering in single mode fibre with pump power recycling technique.", Volume 13 Number 10, Journal of Optics. Impact factor: 1.99, 2011.
- [21] Hamid Ali Abed Al-Asadi, "Architectural Analysis of Multi-Agents Educational Model in Web-Learning Environments," Journal of Emerging Trends in Computing and Information Sciences, Vol. 3, No. 6, June 2012.
- [22] Boselin Prabhu S.R. and Sophia S., 'Hierarchical distributed clustering algorithm for energy efficient wireless sensor networks', International Journal of Research in Information Technology, 1(12), 2013.
- [23] Boselin Prabhu S.R. and Sophia S., 'Real-world applications of distributed clustering mechanism in dense wireless sensor networks', International Journal of Computing Communications and Networking, 2(4), 2013.
- [24] . Prof. Jitendra R. Rana, Prof. S.N.Pawar, ZigBee Based Home Automation, <http://ssrn.com/abstract=1587245>
- [25]. "XBee-2.5-Manual," ZigBee RF communication protocol. (2008). Minnetonka: Digi International Inc.
- [26]. *XBee OEM RF Modules- ZigBee - v1.x1x [2007.06.01]* © 2007 Digi International, Inc.www.digi.com
- [27]. Lakhya¹, Inder², Emanuel³, Abhijit⁴, Lalan⁵, Debraj⁶, Er. M. Sujitha⁷, Home Automation System Based On Arm And Zigbee, *Undergraduate Academic Research Journal (UARJ)*, ISSN: 2278 – 1129, Volume-1, Issue-3,4, 2012.